

EST01 Product Specification

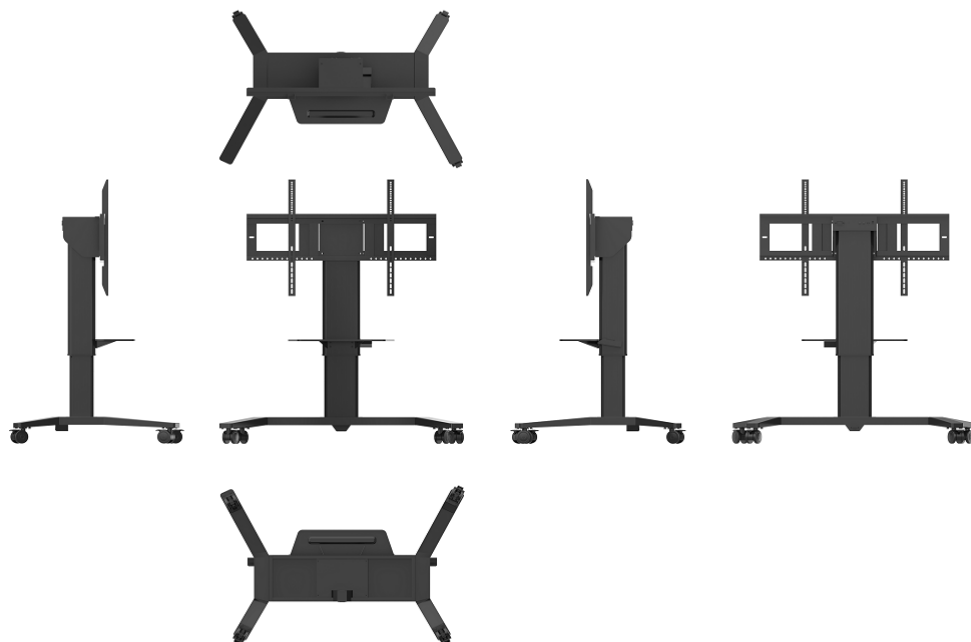

Dimensions:

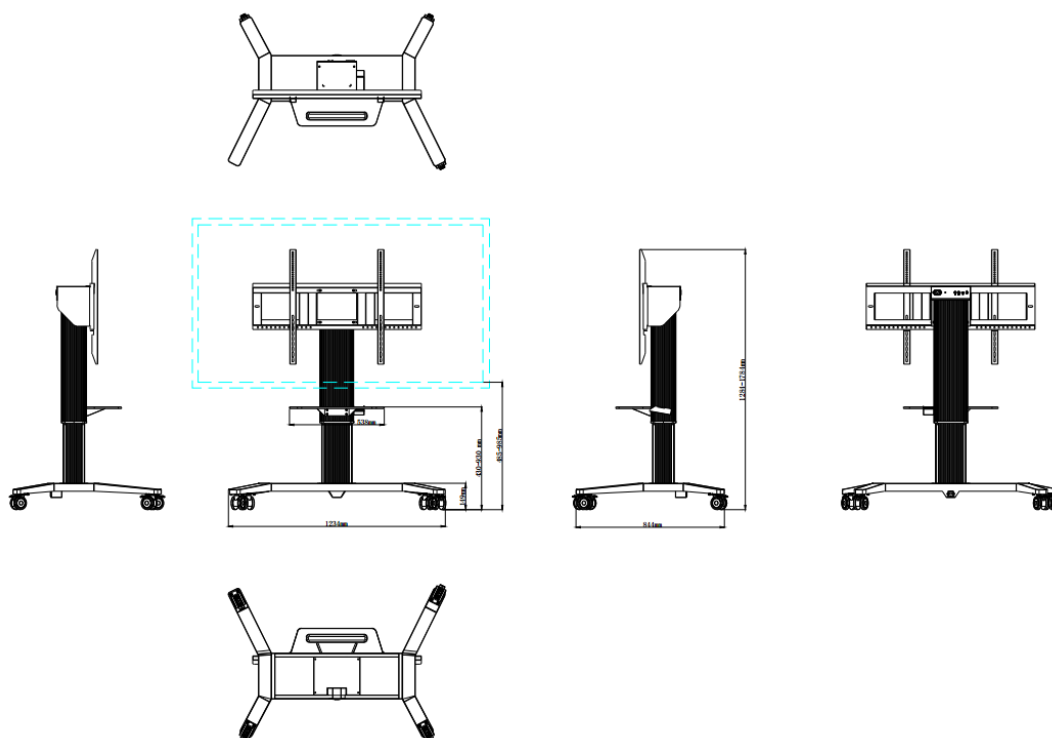

Product Specifications:

Physical Specifications

Dimension (L*W*H)	1234*844*(1284~1784)mm	
Dimension with Package (L*W*H)	1366*933*280mm	
Net Weight	49.2kg	
Gross Weight	55kg	
Max Load	100kg	
Power Requirements	100-240V~50/60Hz	
Lifting Distance	500mm	
Control Mode	Control Panel /Control Pad/ Software	
Max Load Size	Recommend No more than 75 inches	
Truckle	Size	3inch
	Type (mute /Non-mute)	mute
Wall-hanging	Standard	Support
	Compatible	9060A/9060F

Accessories

Control Pad	1
AC Power Cable	1
Quick Start Guide	1
Installation Manual	1
USB Adapter Cable	1
AC Power Adapter Cable	1
Screw Accessory Package	1

Environmental Conditions

Operation Temperature	0°C - 40°C
Operation Humidity	10% - 90%
Storage Temperature	-20°C -60°C
Storage Humidity	10% - 90%
Altitude	Below 5000 meters